



# INSTALLATION INSTRUCTIONS

Product: Adjustable Front Bump Stop System  
Part Number: JKS1140

Applications: Wrangler JL, 2018-2021 (front only)

517-278-1226 • tech@jksmfg.com • www.jksmfg.com  
491 W. Garfield Avenue, Coldwater, MI 49036

## Welcome

CONGRATULATIONS on purchasing a set of new Adjustable BumpStops™ from JKS Manufacturing. We are committed to providing you with the best products available and your satisfaction is our first priority.

PLEASE READ these Installation Instructions carefully, and save them for future reference, as they contain important installation and maintenance information.

## Important

**MAY BE INSTALLED IN FIVE (5) POSSIBLE CONFIGURATIONS** depending on individual spacer(s) used. Use appropriate hardware for your configuration. Refer to page 2 for details.

## Tools Required

- Metric/Standard Socket Wrench Set
- Torque Wrench
- Hydraulic Floor Jack & Jack Stands
- Factory Service Manual (recommended)

\* Asterisk denotes tools that are not required for some applications. Thoroughly read instructions first to determine which tools will be required for your application.

## Parts



	Description	QTY
<b>A</b>	2.00" BumpStop Spacer	2
<b>B</b>	0.50" BumpStop Spacer	8
<b>C</b>	3/8" x 2-1/2" Bolt	2
<b>D</b>	3/8" x 3" Bolt	2
<b>E</b>	3/8" x 3-1/2" Bolt	2
<b>F</b>	3/8" x 4" Bolt	2
<b>G</b>	3/8" x 4-1/2" Bolt	2
<b>H</b>	3/8" Serrated Flange Lock Nut	2
<b>I</b>	3/8" SAE Washer	2



**3" Bump Stop Configuration Pictured**

**❑ 2. DETERMINE BUMPSTOP LENGTH**

The JKS adjustable Front Bumpstop System can be installed in five unique configurations: 2", 2.5", 3", 3.5" and 4" depending on the number of 0.5" spacers used.

- Determine the ideal bump stop length for your application by considering factors such as:
  - Clearance between vehicle tires and body panels during full suspension compression
  - Clearance between axle housing and chassis or drivetrain during full suspension compression
  - Length of existing bump stop extension, if installed
  - Choose the spacer(s) that provides maximum, unobstructed suspension compression for your application from the list below.

<b>Bump Stop Length</b>	<b>Bolt Length</b>
<b>2"</b>	<b>2-1/2"</b>
<b>2-1/2"</b>	<b>3"</b>
<b>3"</b>	<b>3-1/2"</b>
<b>3-1/2"</b>	<b>4"</b>
<b>4"</b>	<b>4-1/2"</b>

**❑ 3. INSTALLING BUMPSTOP SPACERS ON LOWER SPRING MOUNT**

- Place selected bumpstop spacers inside of coil spring.
- Install the front springs with the bump stop extension. Make sure the spring is seated properly in the axle mount and the top isolator hasn't moved from the stock position.
- Using hydraulic floor jack, raise the axle until the spring is fully seated.
- Attach the bump stop extension to the axle through the hole in the center of the spring perch. Access to the nut can be obtained from the front of the spring perch. Another option is to remove the brake line bracket temporarily to gain access to attach the nut from the rear of the spring perch Torque to approximately 29 ft-lbs.
- Finish reinstallation of all components removed/ disconnected according to factory service manual.

**Installation**

**❑ 1. REMOVE COIL SPRINGS**

- Raise and support the vehicle chassis with jack stands.
  - FRONT INSTALLATION – Position behind front lower suspension arm brackets.
- Remove the coil springs per the factory service manual instructions for your vehicle.
- Depending on the application, it may be necessary to completely or partially remove any of the following components before spring can be free from upper mount. *HINT: Refer to factory service manual for procedures not covered in these instructions.*
  - Shock Absorber
  - Swaybar
  - Brake Line
  - ABS Wire
  - Lower Suspension Arm
  - Track Bar
  - Steering Drag Link
  - Spring Retainer Clip

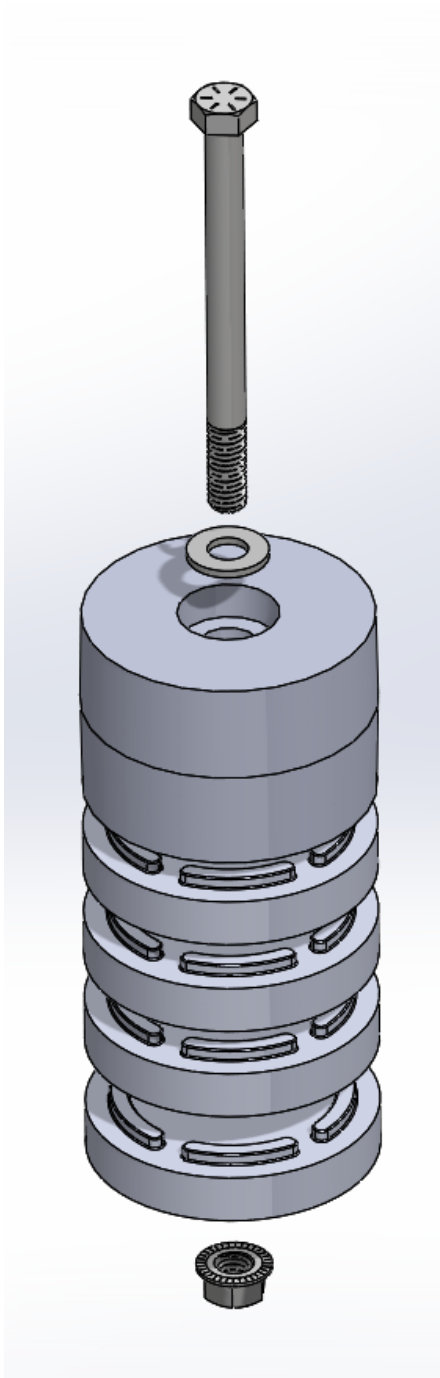

*4" Bump Stop Configuration Shown*

#### ❑ 4. POST-INSTALLATION INSTRUCTIONS

Before operating vehicle off-road, test for proper bump stop operation by fully cycling the suspension and checking for obstructions. Add, remove or replace BumpStop Spacers if necessary until maximum unobstructed suspension compression is achieved.

## Operation

Future BumpStop length adjustments should be made with NO LOAD on the coil springs, and the suspension at FULL DROOP.

## Maintenance

Regular cleaning with pressurized water is recommended to maximize ease of operation and reliability.

---

©2013 JKS Manufacturing, Inc & Aftermarketing, LLC  
Revision Date 3/23/2021